



OPERATOR'S MANUAL

BRAVO 21 Mower

Model:

21-101 BBC

21-501 Zone Start

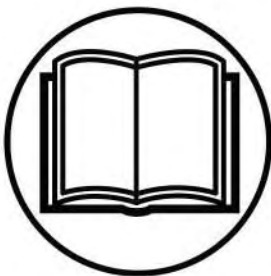

Operator's Manual

Read these instructions carefully and make sure you understand them before using the BRAVO 21.

INTRODUCTION



Careless or improper use of this Lawn Mower can cause serious or even fatal injury. Carefully read, understand and follow ALL instructions in this manual as well as the instructions in the included **HONDA Engine Owner's Manual** before using the **BRAVO 21 Lawn Mower**.

Allow only competent adults to operate this lawn mower. It is the owner's responsibility to ensure that all operators of this mower have read and understand the content of this manual.

Common sense:

The focus of this manual is HOW to operate and service the equipment safely. It is not possible to cover every conceivable situation you can face when using this mower. Therefore use this product only in a manner described in this manual. **Operation or handling the machine in any other manner can lead to serious injury or death.** If a situation is not described in this manual it should be considered dangerous - and not be done.

If you are unfamiliar with this product make sure that you carefully understand how it functions and practice all operations and handling before putting the machine to use. Familiarize yourself in the presence of an experienced operator. Avoid all situations that are beyond your capability.

If you still feel uncertain about the operating procedures after reading these instructions **DO NOT** operate the machine until you have consulted an experienced operator.

If you have further questions you can contact - **Ybravo.com**, by writing or calling, see information below. You may also find a dealer close to you by searching the internet at: **www.ybravo.com** **Ybravo.com**, will willingly be of service and provide you with advice as well as help you to use your product both efficiently and safely. Additional manuals are available at **NO CHARGE** and can also be obtained on the internet site.

Ybravo.com, LLC
P.O.Box 2209
Livermore CA 94551
USA

Toll Free no: **888 ybravo1** (888 927 2861)
Phone no: 925 961 8750
Fax no: 925 961 8770
Internet Site: **www.ybravo.com**

PERSONAL SAFETY EQUIPMENT

When working and operating garden equipment - approved personal safety items should be used:



Hearing
Protection



Eye
Protection



Protective
Gloves



Protective
Shoes



WARNING

CALIFORNIA Proposition 65 Warning

The engine exhaust from this product contains chemicals known to the State of California to cause cancer, birth defects or other reproductive harm.

NOTICE

The engine is not equipped with a spark arrester in the muffler. It is a violation of California Public Resource Code Section 4442 to use or operate the engine on any forest-covered, brush-covered, or grass-covered land. Other states or federal areas may have similar laws. Be aware of local laws and regulations. A spark arrester is available from authorized Honda servicing dealers.

SAFETY DEFINITIONS

In this manual a Safety Alert Symbol  followed by the signal words WARNING and CAUTION are used to identify safety information about hazards which can result in death, serious injury and/or property damage.

These signal words mean:

 **WARNING** indicates a hazard which, if not avoided, **could result in death or serious injury.**

 **CAUTION** indicates a hazard which, if not avoided, **might result in minor or moderate injury.**

NOTICE indicates a message not related to personal injury.

SAFETY HAZARDS

WARNING

DO NOT MODIFY THE PRODUCT

Under no circumstances may the design of the machine be modified without the permission of the manufacturer. Always use genuine parts and accessories. Unauthorized modifications, parts and/or accessories can result in serious personal injury or the death of the operator or others. Your warranty may not cover damage or liability caused by the use of unauthorized accessories or replacement parts.



WARNING

ASPHYXIATION HAZARD

Running an engine in a confined or badly ventilated area can result in injury or death due to asphyxiation or carbon monoxide poisoning.



CAUTION

HEARING HAZARD

During the normal use of this machine, operator may be exposed to a noise level equal to or higher than 85 dB(A). Use hearing protection.

REGISTER THE PRODUCT

Please register your new lawn mower with Ybravo.com, by mailing in a copy of this page together with your address information or (better) register the mower online at the internet site:

www.ybravo.com

Registration will allow us to contact you in case of any critical updates or recalls on this machine. Product registration has been found helpful in tracing stolen equipment.

Record the following information for your records:

PURCHASE DATE: _____

MODEL No: _____

SERIAL No: _____

ENGINE MODEL: _____ ENGINE TYPE: _____ ENGINE SERIAL No: _____

The lawn mower model and serial number as well as the engine model number, engine type and serial number are critical in order to obtain the correct service parts. Ybravo.com has service parts available as listed in the spare parts list. All engine parts are distributed through the Honda engine dealer network. Please refer to the Honda Owner's Manual that was included with the mower.

Mail information:

Street Address: _____

Name: _____ City, State, Zip code _____

CONTENTS

Content	Page
Introduction, personal safety	2
General safety message.....	2-3
Registration of the product	3
Table of contents	4
Lawn mower safety.....	4-5
Decals and locations.....	6
What is what on the product.....	6
Assembly - setup	7-8
Fuel and fuel safety warnings.....	8
Recommended fuels.....	8
Recommended engine oil	8
Controls and operation	9-10
Maintenance	11-13
Maintenance schedule.....	11
Blade maintenance	12
Oil change.....	13
Warranty	15



WARNING

In order to prevent accidental starting when setting up, transporting, adjusting or making repairs, always disconnect spark plug wire and place wire where it can not come in contact with plug.



WARNING

Always secure the mower when unattended. Never leave the mower in such way that an unauthorized person can operate or move the mower.

LAWN MOWER SAFETY

SAFETY PRACTICES FOR WALK-BEHIND MOWERS

This lawn mower is capable of amputating hands and feet and throwing objects. Failure to observe the following safety instructions could result in serious injury or death.

I. GENERAL OPERATION

1. Read, understand, and follow all instructions on the machine and in the manuals before starting.
2. Do not put hands or feet near or under the machine. Keep clear of the discharge opening at all times.
3. Only allow responsible adults, who are familiar with these instructions, to operate this machine.
4. Clear the area of objects such as rocks, wire, toys, etc., which could be thrown by the blade. Stay behind the handle when the engine is running.
5. Be sure the area is clear of other people before operating. Stop machine if anyone enters the area.
6. Do not operate machine barefooted or while wearing sandals. Always wear substantial footwear (protective shoes).
7. Do not pull machine backward unless absolutely necessary. Always look down and behind before and while moving backward.
8. Keep the operating area clear of bystanders. Stop the blade when crossing gravel surfaces.
9. Do not operate machine without the entire grass catcher, or mulch plug and discharge door, rear guards, or other safety protective devices in place and working.
10. Never leave a running machine unattended.
11. Stop the engine and wait until the blade comes to a complete stop before cleaning the machine, removing grass catcher, or unclogging the discharge chute.
12. Operate machine only in daylight or good artificial light.
13. Do not operate machine while under the influence of alcohol or drugs.
14. Never operate mower in wet grass. Always be sure of your footing - walk - never run.
15. Disengage the drive system, before starting the engine.
16. If the machine should start to vibrate abnormally, stop the engine and check for the cause immediately. Vibration is generally a warning of trouble.
17. Always wear approved personal safety equipment such as hearing protection, eye protection, and protective gloves when operating machine.
18. See manufacturer's instructions for proper operation and installation of accessories. Only use accessories approved by Ybravo.com or Honda.

LAWN MOWER SAFETY

II SLOPE OPERATION

Slopes are a major factor related to slip and fall accidents, which can result in severe injury. Operation on all slopes requires extra caution. If you feel uneasy on a slope, do not mow it.

1. Mow across the face of slopes; never up and down. Exercise extreme caution when changing direction on slopes.
2. Watch for holes, ruts, bumps, rocks, or other hidden objects. Uneven terrain could cause a slip and fall accident. Tall grass can hide obstacles.
3. Do not mow on wet grass or excessively steep slopes. Poor footing could cause a slip and fall accident.
4. Do not mow near drop-offs, ditches, or embankments. You could lose your footing or balance.

III. CHILDREN

Tragic accidents can occur if the operator is not alert to the presence of children. Children are often attracted to the machine and the mowing activity. Never assume that children will remain where you last saw them.

1. Keep children out of the mowing area and under the watchful care of a responsible adult other than the operator.
2. Be alert and turn mower off if a child enters the area.
3. Never allow children to operate the machine.
4. Use extra care when approaching blind corners, shrubs, trees, or other objects that may block your view of a child.

IV. SAFE HANDLING OF GASOLINE:

To avoid personal injury or property damage, use extreme care in handling gasoline. Gasoline is extremely flammable and the vapors are explosive.

1. Extinguish all cigarettes, cigars, pipes, and other sources of ignition.
2. Use only an approved gasoline container.
3. Never remove gas cap or add fuel with the engine running. Allow engine to cool before refueling.
4. Never refuel the machine indoors.
5. Never store the machine or fuel container where there is an open flame, spark, or pilot light such as on a water heater or on other appliances.
6. Never fill containers inside a vehicle or on a truck or trailer bed with a plastic liner. Always place containers on the ground away from your vehicle before filling.
7. Remove the mower from the truck or trailer and refuel it on the ground. If this is not possible, then refuel the mower with a portable container, rather than from a gasoline dispenser nozzle.

Continued,

8. Keep the nozzle in contact with the rim of the fuel tank or container opening at all times until fueling is complete. Do not use a nozzle lock-open device.
9. If fuel is spilled on clothing, change clothing immediately.
10. Never overfill fuel tank. Replace gas cap and tighten securely.

V. GENERAL SERVICE

1. Never operate the mower in a closed area.
2. Keep all nuts and bolts tight to be sure the mower is in safe working condition.
3. Never tamper with safety devices. Check their proper operation before each use of the mower.
4. Keep the mower free of grass, leaves, or other debris build-up. Clean up oil or fuel spillage and remove any fuel-soaked debris. Allow machine to cool before storing.
5. If you strike a foreign object, stop and inspect the mower. Repair, if necessary, before starting.
6. Never make any adjustments or repairs with the engine running. Disconnect the spark plug wire and ground against engine to prevent unintended starting.
7. Never attempt to make wheel height adjustments while the engine is running.
8. Check grass catcher components and the rear discharge door frequently and replace only with Ybravo.com original parts when necessary.
9. Mower blades are sharp. Wrap the blade or wear gloves, and use extra caution when servicing them.
10. Do not change engine governor setting or over speed the engine.
11. Maintain or replace all safety and instruction labels.

CAUTION

Muffler and other engine parts become extremely hot during operation and remain hot after engine has stopped. To avoid severe burns on contact, stay away from these areas.



DECALS AND LOCATIONS

These labels warn you of potential hazards that can cause serious injury. Carefully read and understand them. If a label comes off or becomes hard to read, contact Ybravo.com immediately for a free replacement.

Part #: 201156-1 Zone Start Version
Part #: 201158-1 BBC Version



Warning label on grass bag



Model & Serial #

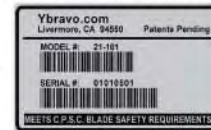

Part #: 201159-1



WHAT IS WHAT

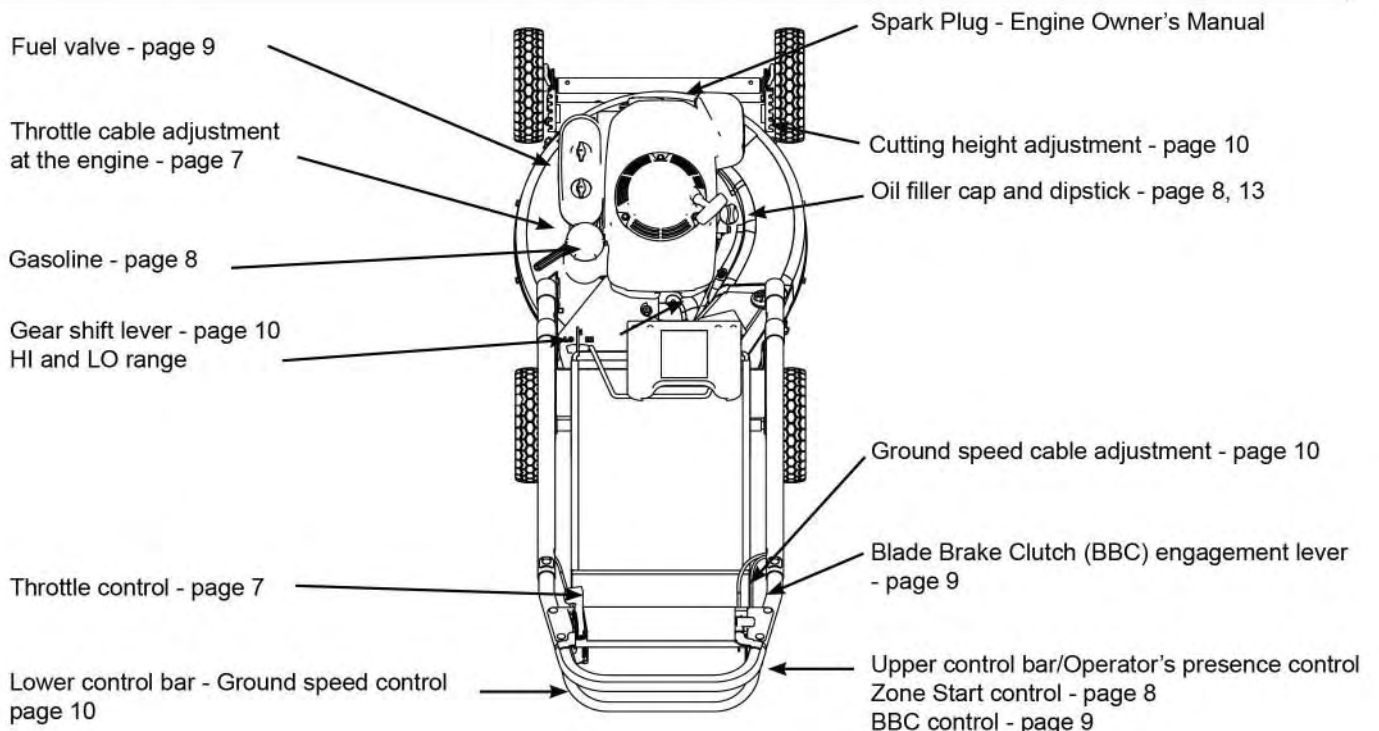

ASSEMBLY - SETUP

UNPACKING:

Carefully remove the machine from its packaging and check that you have all the following items:

Upper Handle complete

(2) Lower Handle tubes (red)

Mower Bag and Mulch Plug (installed on the mower)

Tool kit

Honda engine Owner's Manual

Bravo 21 Operator's Manual.

NOTICE:

If you are missing any of these items or if you are unsure of how to properly assemble this mower please contact **Ybravo.com** by e-mail or by phone: **888.ybravo1** (888.927.2861)

Tools needed for assembly:

10mm wrench

13mm wrench

Philips screwdriver



STEP 1

Install the red handle tubes to the mower with the M8 carriage bolts. Do not tighten the screws. Please note that there are three holes for the upper clamp. We suggest to install the screw in the middle hole as a start.

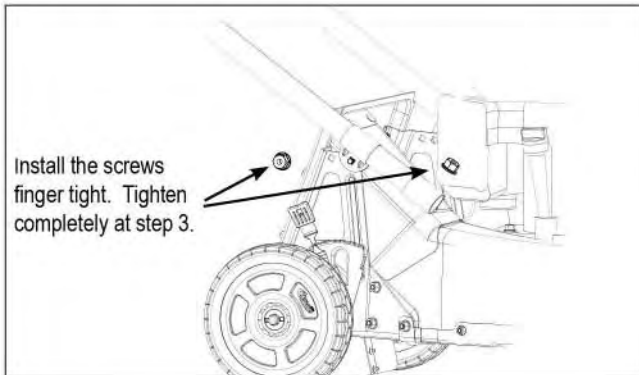

STEP 2

Slide the upper handle assembly into the two lower tubes. Insert the two carriage screws and use one square washer on each side of the handle tube.

On the Zone start version the screw on the right side has an eyelet and is used to hold the starter rope.

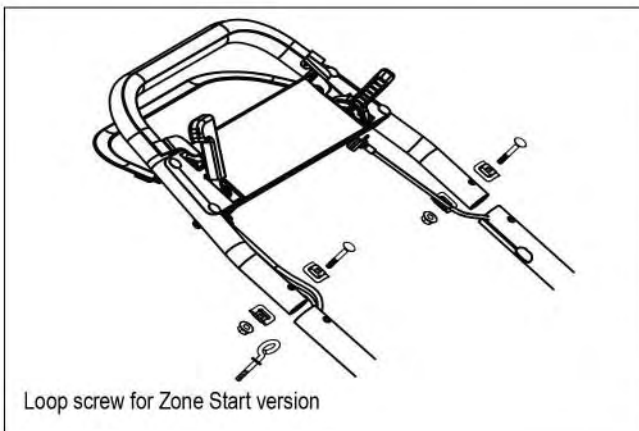

STEP 3

To simplify the installation and alignment of the handle, install the grass catcher.

Tighten the screws in the following order:

- Tighten the two screws on the right side tube clamps

- Align the left tube with the catcher (same as the right side) and tighten the lower clamps.

- Tighten the upper screws that attaches the handle assembly to the tubes.

STEP 4

Insert the throttle cable inside the left handle tube. The cable will come out at the bottom of the tube. Install the throttle cable to the engine per the illustration.

Install the edge of the cable in line with the edge of the clamp as illustrated.

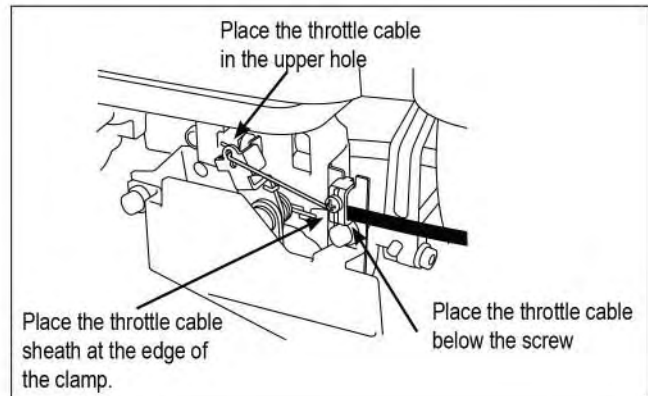

STEP 5

Verify that the throttle control is adjusted properly as follows:

- Move the throttle control to the Full Throttle position.

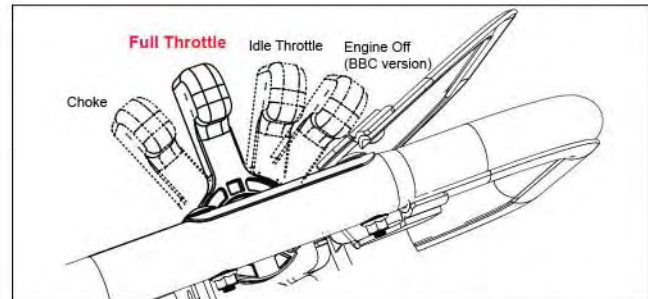

- In the full throttle position the two arms at the throttle mechanism on the engine should touch as illustrated below.

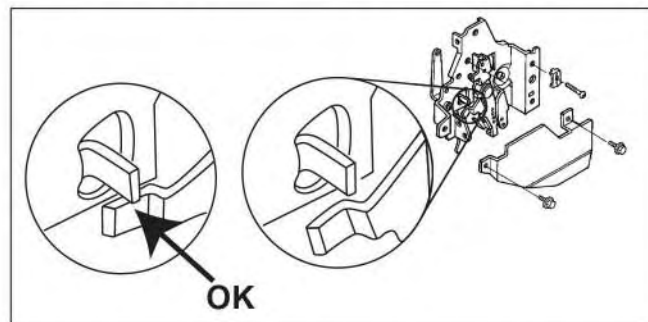

Following these steps for the throttle adjustment will ensure that the Honda engine performs properly for this mower. The engine speed is adjusted to 3100 RPM at the factory.

ASSEMBLY - SETUP

STEP 6 ZONE START ONLY

On the Zone Start version the cable from the control panel is attached by the engine oil filler cap. When the upper control bar is depressed towards the handle it will release the flywheel break/stop switch of the engine. The cable is adjusted at the factory however it is important to understand the function and how the adjustment can be checked.

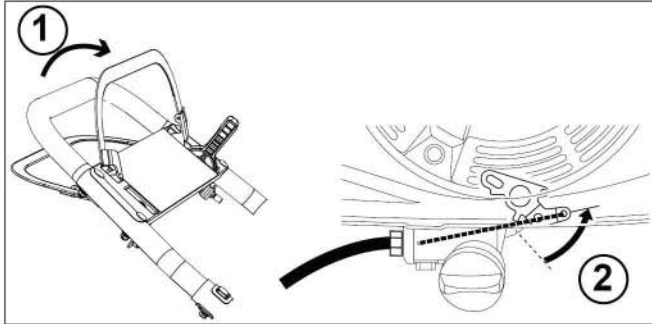

With the upper control bar in the released position (1) the arm on the engine at (2) should be able to move forward towards a limiter. This position of the arm ensures that the flywheel brake and stop switch on the engine are fully engaged.

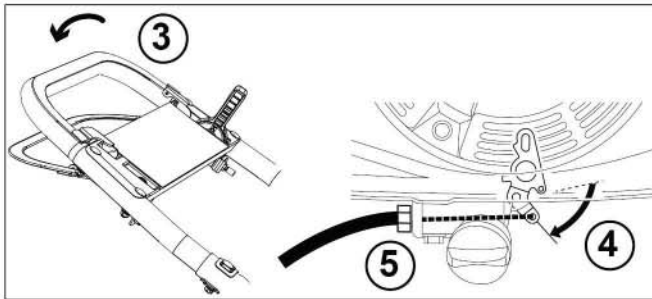

With the upper control bar pushed down towards the handle (3) the arm on the engine should move towards a limiter in the direction of the arrow (4). This is a completely released position of the flywheel brake system. The length of the cable can be adjusted at (5) with a 10mm wrench.

STEP 7

To assist with the installation of the drive cable to the lower control bar push the control bar past the spring lock (1) that normally retains the control bar in a comfortable operating position.

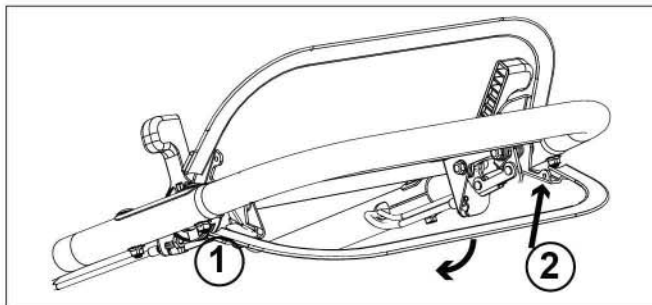

Insert the end of the spring into the hole (2) in the control bar.
 - Pull back on the cable adjustment knob and insert into the slot of the control panel.
 - Pull up on the control bar to check the function.

STEP 8

Fill the engine with an SAE 10W-30 engine oil. Fill; 22 Fl.Oz (0.7 Qt. - 0.65Liters)
 Please read the Honda engine Owner's Manual for full information.

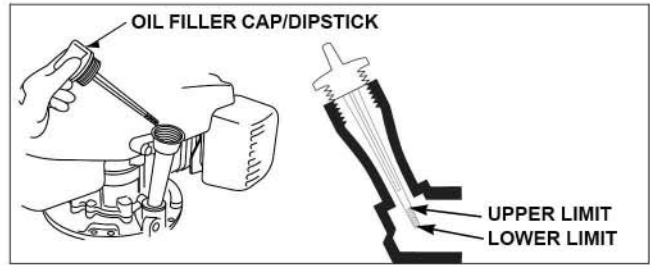

STEP 9

Before filling the engine with gasoline - follow all instructions in this manual as well as all instructions provided in the Honda engine Owner's Manual.
 Maximum fill volume: 1.5 Qt (1.4 Liters) - 86 octane or higher.

The engine will not operate on gasoline marketed as E-85 (85% ethanol)

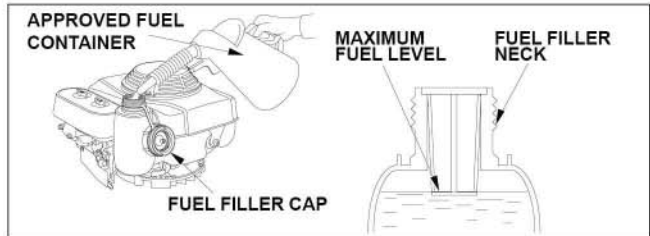

WARNING

Taking the following precautions will lessen the risk of injury and property damage. Use extreme care in handling gasoline. Gasoline is extremely flammable and the vapors are explosive.

- Extinguish all cigarettes, cigars, pipes, and other sources of ignition.
- Use only approved gasoline containers.
- Never remove gas cap or add fuel with the engine running.
- Allow engine to cool a minimum of 3 minutes before refueling.
- Never fuel the machine indoors.
- Never store the machine or fuel container where there is an open flame, spark, or pilot light such as on a water heater or other appliances.
- Never fill containers inside a vehicle or on a truck or trailer bed with a plastic liner. Always place containers on the ground away from your vehicle when filling.
- Remove the mower from the truck or trailer and refuel it on the ground. If this is not possible, then refuel the equipment with a portable container, rather than from a gasoline dispenser nozzle.
- Keep the nozzle in contact with the rim of the fuel tank or container opening at all times until fueling is complete. Do not use a nozzle lock-open device.
- If fuel is spilled on clothing, change clothing immediately.
- Never overfill fuel tank. Always wipe off any spilled fuel or oil. Replace fuel cap and tighten.

CONTROLS & OPERATION

Before operating the mower for the first time, please review and understand the entire manual including all Warnings and Cautions.

Even if you have operated other mowers in the past please take time to become familiar with how this mower works and practice all operations to build up your skills.

BEFORE ANY OPERATION ALWAYS:

- Inspect the mower for any visible damage or broken parts
- Check the oil level in the engine on a daily basis
- Make sure that when you release the Upper Control Bar the engine will stop (on the Zone Start version) or that the blade will disengage (on the BBC version). When you release the blade control bar, the blade should stop. If it does not, contact a Ybravo.com Authorized Service Dealer or contact Ybravo.com for advice.
- Never operate the mower with obvious damage or malfunction until the problems are resolved.

WARNING

Never make adjustments or repairs with the engine running. Disconnect the spark plug wire, and keep the wire away from the plug to prevent accidental starting..

OPERATING FUEL VALVE

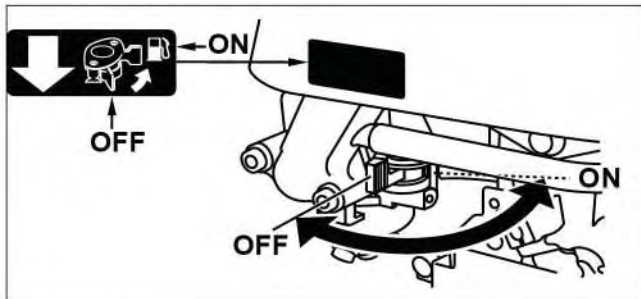

THROTTLE CONTROL

To start a cold engine it is important to use the "Choke" position. To start a warm engine it is not necessary to use the choke.

For best performance use the "Full Throttle" position for all mowing. To verify that the engine is running at full throttle please follow the steps outlined under the set up instructions (Step 4 and 5) on Page 7

A Ybravo.com dealer can typically also verify the correct full throttle adjustment. The engine speed should be 3100 rpm.

Notice: The upper control bar is an "Operators Presence Control" on the Zone Start version. It has to be pushed down before starting the engine.

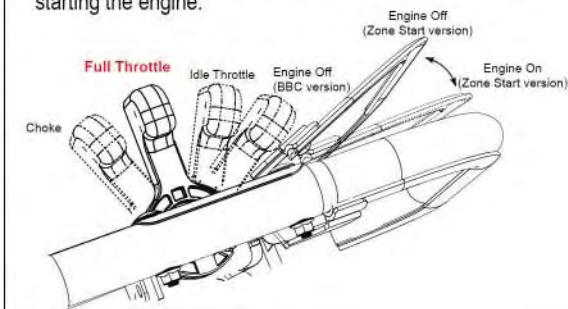

BLADE CONTROL - BBC VERSION (Blade Brake Clutch version)

It is a multi step process to engage the blade. Do not start the engine and the blade on an uncut lawn. If the blade is blocked by tall grass or debris it can damage the clutch during the starting.

1. Start the engine and let it warm up for 10 to 30 seconds
2. Set the throttle control to the "Full Throttle" position
3. Push down on the Operator Presence Control bar
4. Push forward on the blade control lever until it latches. You will distinctly hear the blade operating (fan like noise). The engagement lever will spring back to its original position after engagement of the clutch.
5. When the upper control bar is released the blade should stop.

Alternative BBC Function Test

An alternative test of the BBC function is to install an empty grass collection bag. Do not install the mulch plug in the discharge tunnel.

1. Start the engine.
2. Engage the blade per above procedure. Notice how the noise changes and that the bag becomes "inflated".
3. Release the upper control bar. If the bag does not "deflate" immediately, it indicates that the blade is still engaged and rotating.

WARNING

If the blade continues to run (no change in the noise or size of the grass bag) after releasing the upper control bar it is an indication of a malfunction of the BBC system. Immediately stop the engine by using the throttle control on the left side of the control panel. The BBC system will require a repair before further use. Immediately contact Ybravo.com for advice. Do not under any circumstances defeat the function of the BBC system. This can cause serious injury or death.

CONTROLS & OPERATION

DRIVE CONTROL

The drive system consists of a two speed transmission and an adjustable belt drive from the engine to the transmission.

The transmission speed can be set to HI - N - LO.
HI speed is approximately 4mph - a fast walking speed.
LO speed is approximately 3mph - an average walking speed.

The shifter arm is intentionally made flexible. When the arm is locked in the **LO** or the **HI** position the transmission will automatically mesh into the gears as soon as the drive is engaged by operating the lower control bar.

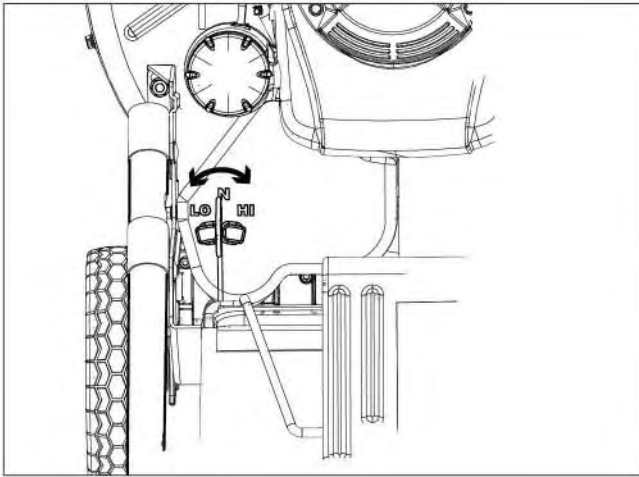

To engage and disengage the drive system pull up on the lower control bar. By adjusting the knob (1) for the drive cable it is possible to adjust how far away from the handle the drive control bar engages the transmission (2).

Recommended adjustment is the drive starts to engage when the lower control bar is approximately 1 inch (25mm) away from the handle

We do not recommend to adjust the cable so that the belt drive slips at all times. This can cause premature wear to the belt.

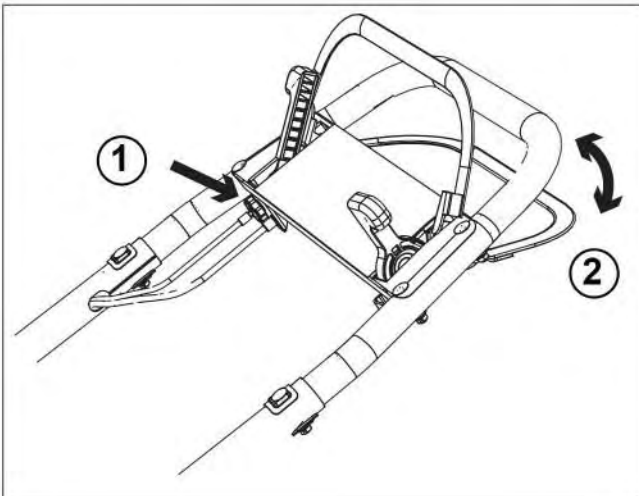

HEIGHT ADJUSTMENT

Each wheel can be adjusted individually to a specific cutting height.

Note that moving the front wheel height adjusters forward raises the cutting height. Moving the rear wheel height adjusters towards the rear of the mower raises the rear cutting height. Always adjust the height adjusters to the same position both in the front and the rear for proper cutting results.

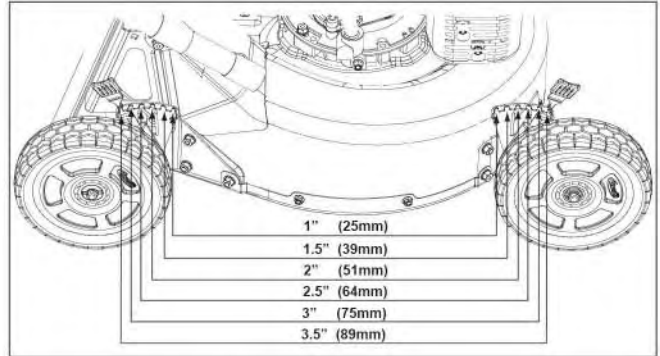

! WARNING

Never readjust the cutting height while the engine is running. **STOP** the engine. Never lift the mower by placing your hand or fingers under the edge of the mower deck.

MODES OF OPERATION

This mower is approved to be used in two different operational modes:

1 With a grass catcher in place

An original equipment Ybravo.com catcher has been tested to be used with this mower. It is important to always inspect the catcher for deterioration. If the material is ripped or worn the bag shall not be used.

2. With the mulch plug installed

If the mulch plug is installed ensure that the rear door can close completely.

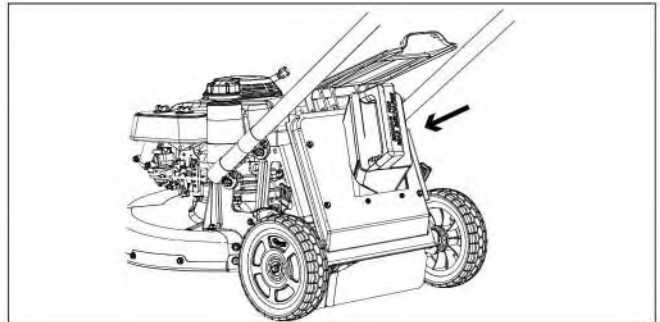

! WARNING

Do not operate the lawn mower without the mulch plug or the Ybravo.com grass catcher in place. Never attempt to operate the mower with the rear door removed, damaged or propped open.

MAINTENANCE

Maintenance - Service Interval	Procedures
Before each use	Check the engine oil level. Check the operation and function of the Operators Presence Control bar. Inspect the mower blade for wear or damage. Inspect the cables for any wear or damage. Inspect the grass catcher for any damage. Check for any loose or missing screws or damaged parts. Clean under the lawn mower deck (after usage).
First 20 Hours or Within 4 weeks	Change the engine oil. Check the throttle cable adjustment (see page 7)
Every 50 Hours or every 2 months	Lubricate the pivot arms on the control panel with oil. Check and Clean the engine air filter (see Honda engine Owner's Manual)
Every 100 Hours or every 4 months	Change the engine oil (more often in dusty conditions). Check the spark plug. Clean the engine with compressed air.
Every 200 Hours or every 8 months	Replace the paper air filter (more frequently in dusty conditions). Replace the spark plug. Adjust the valve clearance.

In addition to this schedule follow the Maintenance Schedule in the Honda Owner's Manual. This maintenance schedule assumes daily use by a landscape company. One Month of use is assumed to be 15 to 20 days of operation.

NOTICE

Several of the operations described in this Maintenance section involves placing the mower on its right side.

To avoid spills of oil and gasoline always:

- Place the mower on a hard surface such as a concrete driveway or a garage floor.
- Never place the mower on its side when there is gasoline in the tank - do the service of the mower when you have run out of gasoline during normal operation.
- Always make sure that the Oil Filler Cap is tightened.

Any spillage of oil or gasoline can be extremely flammable and explosive and under certain conditions can cause serious personal injury and property damage.

CLEANING THE MOWER

We do not recommend using a garden hose to clean the mower. The buildup of moist grass, fertilizer and water can cause extreme corrosion damage to many parts of the mower and the engine.

Never use a Pressure Washer:

The use of a pressure washer can force water and moisture into ball bearings and engine parts and cause substantial damage.

- Clean the underside of the mower by scraping any build-up of grass and trash.
- Clean off the outside of the engine and the top of the mower with compressed air. Any accumulation of debris under the belt cover can typically also be removed with compressed air without removing the protective belt cover.
- Wash the Grass Bag with a garden hose frequently. The holes that allows the grass bag to breathe will eventually clog with dirt. A clogged bag will not collect the grass clippings effectively. Do not install and use a wet grass catcher. It will plug prematurely.

MAINTENANCE

BLADE MAINTENANCE

For best results, the mower blade must be kept sharp. Always replace a bent or damaged blade.

Removing the blade

1. Disconnect spark plug wire from spark plug and place wire where it cannot come in contact with plug.
 2. Turn lawn mower on its right side. (Make sure air filter and carburetor are up).
 3. Use a wood block between blade and mower deck to prevent blade from turning when removing blade bolts.
- NOTE:** Protect your hands with gloves and/or wrap the blade with a heavy cloth.
4. Remove blade bolts by turning counter-clockwise with a 11/16" (17mm) wrench or socket.

Installing the blade

1. Position the blade with the bent corner of the blade (sail) pointing towards the deck. Install the blade bolts.
- Important:** Blade bolts are heat treated. If the bolts are worn or damaged use only bolts available from Ybravo.com
2. Use a block of wood between blade and mower deck and tighten the blade bolts. Always use a torque wrench. The recommended tightening torque is 30 to 35 ft. lbs.



WARNING

Use only a replacement blade approved by Ybravo.com. Using a blade not approved by Ybravo.com is hazardous. It can damage your mower and cause serious personal injury.

A worn or damaged blade can break and parts of the blade could be thrown into the operators or bystanders area, resulting in serious personal injury or death.

Inspecting the blade

Carefully examine the blade for straightness, damage and abnormal wear. In some areas abrasive sand and dust can wear away the metal of the blade - see illustration.

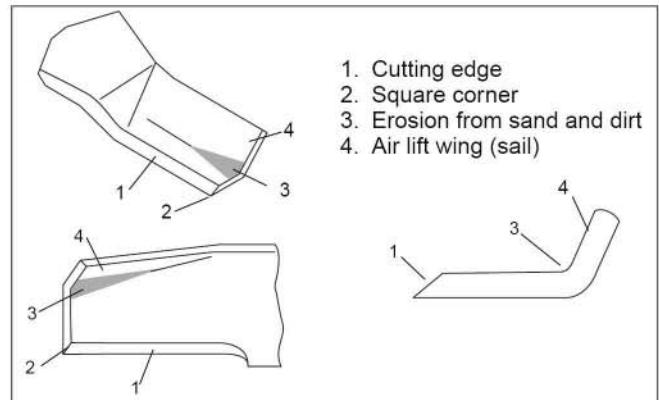

Sharpening the blade

File the top side of the blade (1) and maintain the original angle of the cutting edge. Maintain the radius where the cutting edge ends. Always remove the same amount of material from both ends of the blade. This ensures that the blade stays balanced.

If sharpening is done with a grinding stone the blade should always be balanced using a blade balancing device. A blade balance tool is available from Ybravo.com or most lawn and garden dealers, and hardware stores.

If the blade shows wear or cracking at the edge where the blade is bent up (3) it must immediately be replaced.

MAINTENANCE

ENGINE OIL CHANGE

NOTE: Before tipping lawn mower on its right side to drain oil, empty fuel tank by running engine until fuel tank is empty.

1. Disconnect spark plug wire from spark plug and place wire where it cannot come in contact with plug.
2. Remove oil filler cap/dipstick.
3. Tip lawn mower on its right side as shown and drain oil into a suitable container. Rock lawn mower back and forth to remove any oil trapped inside of engine.
4. Wipe off any spilled oil from lawn mower or side of engine.
5. Fill engine with oil. Slowly pour oil down the oil fill spout into the engine. Use an SAE 10W-30 oil (22 fl oz - 0.65 Liters)
6. Wait one minute to allow oil to settle. Use gauge on oil filler cap/dipstick for checking level. Insert dipstick into the tube and rest the oil fill cap on the tube. DO NOT thread the cap into the tube when taking the reading.
7. Continue adding small amounts of oil and rechecking the dipstick until it reads full. DO NOT overfill, or engine will smoke on startup.
8. Always be sure to retighten oil fill cap/dipstick before starting engine.
9. Reconnect spark plug wire to spark plug.

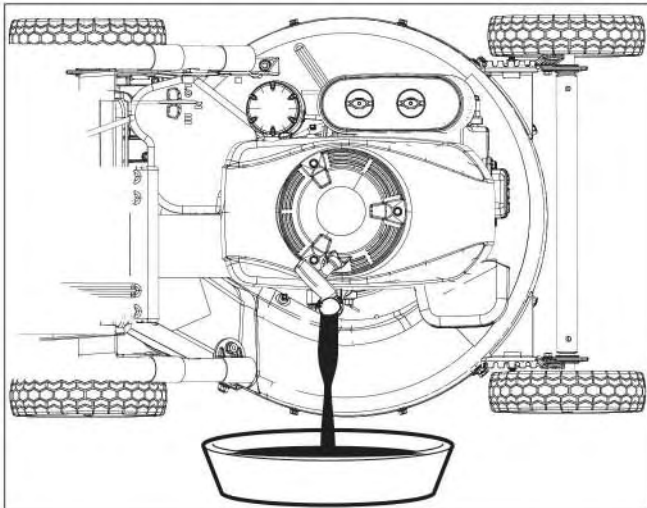

NOTES



PRODUCT REGISTRATION & WARRANTY STATEMENT

All Ybravo.com products can be registered online at www.ybravo.com quickly and easily. Click on the Product Registration tab and fill out the electronic form and submit.

SECTION 1: LIMITED WARRANTY

Ybravo.com (Ybravo) warrants the original purchaser of Ybravo branded product to which this warranty applies (the "Product") that the Product shall be free from defects in material and workmanship from the date of purchase for the period of the applicable "Warranty Schedule" of the Product as set forth below. Additional limitations are described in Section 2 through Section 6, inclusive.

Product Category	Commercial Use Warranty Schedule	Rental Warranty Schedule
Commercial Blowers	1 Year	90 Days
Commercial Mowers	1 Year	90 Days
Replacement Parts (Excludes components which are part of engine systems manufactured by third party engine manufacturers for which the purchaser has received a separate warranty with product at time of purchase.)	60 Days	30 Days

SECTION 2: YBRAVO'S OBLIGATIONS UNDER THE WARRANTY

Ybravo.com will repair or replace defective components without charge for parts or labor if a component fails because of a defect in material or workmanship during the warranty period.

SECTION 3: ITEMS NOT COVERED BY THIS WARRANTY

The following items are not covered by this warranty:

- 1) Normal customer maintenance items which become worn through normal regular use, including, but not limited to, belts, blades, blade adapters, cables, clutches, clutch drums, filters (fuel line, fuel filters, air filters, oil filters), lubricants, rewind springs, spark plugs, and starter ropes.
- 2) Natural discoloration of material due to ultraviolet light;
- 3) Engine and drive systems not manufactured by Ybravo; these items are covered by the respective manufacturer's warranty as provided in writing with the product information supplied at the time of purchase; all claims must be sent to the appropriate manufacturer.
- 4) Commercial mowing decks with sand abrasion damage.
- 5) Emission Control System components necessary to comply with CARB-TIER II and EPA regulations which are manufactured by third party engine manufacturer.

SECTION 4: EXCEPTIONS AND LIMITATIONS

This warranty shall be inapplicable to defects resulting from the following:

- 1) Accident, abuse, misuse, negligence and neglect, including stale fuel, dirt, abrasives, moisture, rust, corrosion, or any adverse reaction due to incorrect storage or use habits;
- 2) Failure to operate or maintain the unit in accordance with the Owner's/Operator's manual or instruction sheet furnished by Ybravo.com;
- 3) Alterations or modifications that change the intended use of the product or affects the product's performance, operation, safety, or durability, or causes the product to fail to comply with any applicable laws; or:
- 4) Additional damage to parts or components due to continued use occurring after any of the above.

REPAIR OR REPLACEMENT AS PROVIDED UNDER THIS WARRANTY IS THE EXCLUSIVE REMEDY OF THE PURCHASER. YBRAVO SHALL NOT BE LIABLE FOR ANY INCIDENTAL OR CONSEQUENTIAL DAMAGES FOR BREACH OF ANY EXPRESS OR IMPLIED WARRANTY ON THESE PRODUCTS EXCEPT TO THE EXTENT PROHIBITED BY APPLICABLE LAW. ANY IMPLIED WARRANTY OF MERCHANTABILITY OR FITNESS FOR A PARTICULAR PURPOSE ON THESE PRODUCTS IS LIMITED IN DURATION TO THE WARRANTY PERIOD AS DEFINED IN THE LIMITED WARRANTY STATEMENT. YBRAVO RESERVES THE RIGHT TO CHANGE OR IMPROVE THE DESIGN OF THE PRODUCT WITHOUT NOTICE, AND DOES NOT ASSUME OBLIGATION TO UPDATE PREVIOUSLY MANUFACTURED PRODUCTS.

Some states do not allow the exclusion of incidental or consequential damages, or limitations on how long an implied warranty lasts, so the above limitations or exclusions may not apply to you. This warranty gives you specific legal rights, and you may also have other rights which vary by state.

SECTION 5: CUSTOMER RESPONSIBILITIES

The product must exhibit reasonable care, maintenance, operation, storage and general upkeep as written in the maintenance section of the Owner's/Operator's manual. Should an operational problem or failure occur, the product should not be used. Failure caused by continued use is not covered by warranty. Product should be delivered, at owners' expense, as is, to an authorized Ybravo Dealer for evaluation. Proof of purchase, as explained in section 6, rests solely with the customer.

SECTION 6: PROCEDURE TO OBTAIN WARRANTY CONSIDERATION

It is the Owner's and Dealer's responsibility to make certain that the Product Registration was completed on-line at www.ybravo.com. Product Registration should be completed within ten (10) days from the date of purchase in order to confirm the warranty and to facilitate post-sale service. Proof of purchase must be presented to the authorized Ybravo dealer in order to obtain warranty service. This proof must include date purchased, model number, serial number, and complete name and address of the selling dealer. To obtain the benefit of this warranty, the product believed to be defective must be delivered to an authorized Ybravo dealer in a timely manner, no later than thirty (30) days from date of the operational problem or failure. The product must be delivered at the owner's expense. Downtime, pick-up and delivery charges are not covered by this warranty. An authorized Ybravo dealer can be located by calling 1-888-YBRAVO-1 or by visiting www.ybravo.com. Subject to change without notice.