

SERVICE TIPS

Updated: 10/2010

DIFFICULTY LEVEL - 3

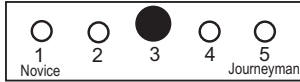

15 to 25 Min

Before working - always follow all instructions and warnings described in the Operator's Manuals for this mower.

UNPACKING:

Carefully remove the machine from its packaging and check that you have the following items:

Upper Handle complete

(2) Lower Handle tubes

Mower Bag and Mulch Plug (installed on the mower)

Tool kit

Honda engine Owner's Manual

Bravo 25 Operator's Manual.

NOTICE:

If you are missing any of these items or if you are unsure of how to properly assemble this mower please contact:

service@ybravo.com by e-mail or by phone: **1.888.ybravo.1** (1.888.927.2861)

Tools needed for assembly:

10mm wrench

13mm wrench

Philips screwdriver

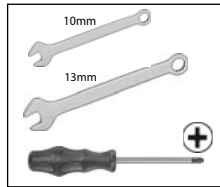

STEP 1

Install the red handle tubes to the mower with the M8 carriage bolts. Do not tighten the nuts. There are three holes for the upper clamp to enable height adjustment. A good starting point is the middle hole for a medium height setting.

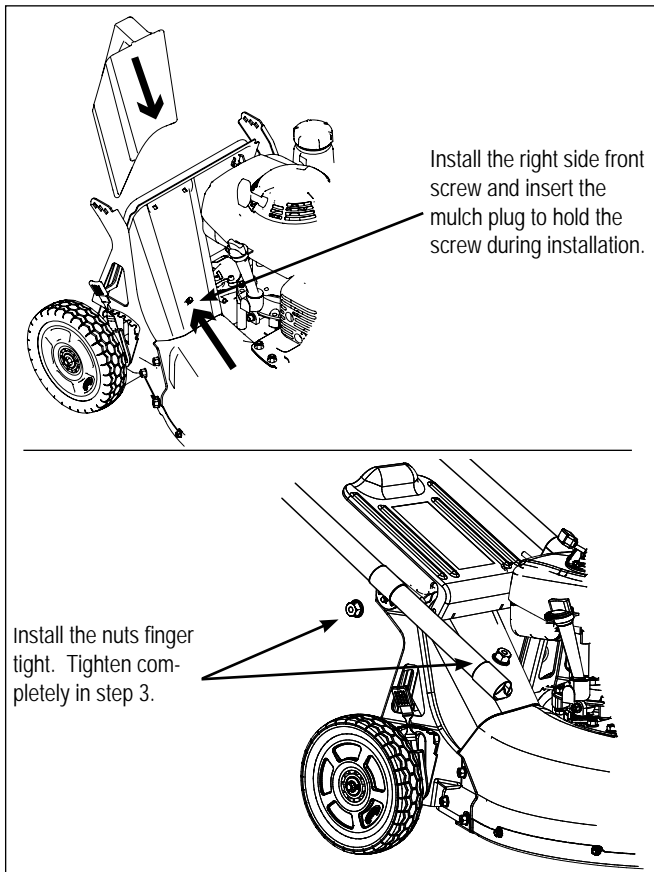

STEP 2

Slide the upper handle assembly into the two lower tubes.

Insert the two carriage screws and use one square washer on each side of the handle tube.

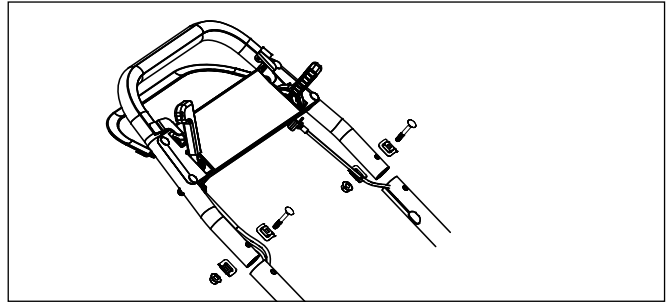

STEP 3

To simplify the alignment of the handle, install the grass catcher. Tighten the screws in the following order:

- 1 - Tighten the two screws on the right side tube clamps
- 2 - Align the left tube with the catcher (same as the right side) and tighten the lower clamps.
- 3 - Tighten the upper screws that attach the handle assembly to the tubes.

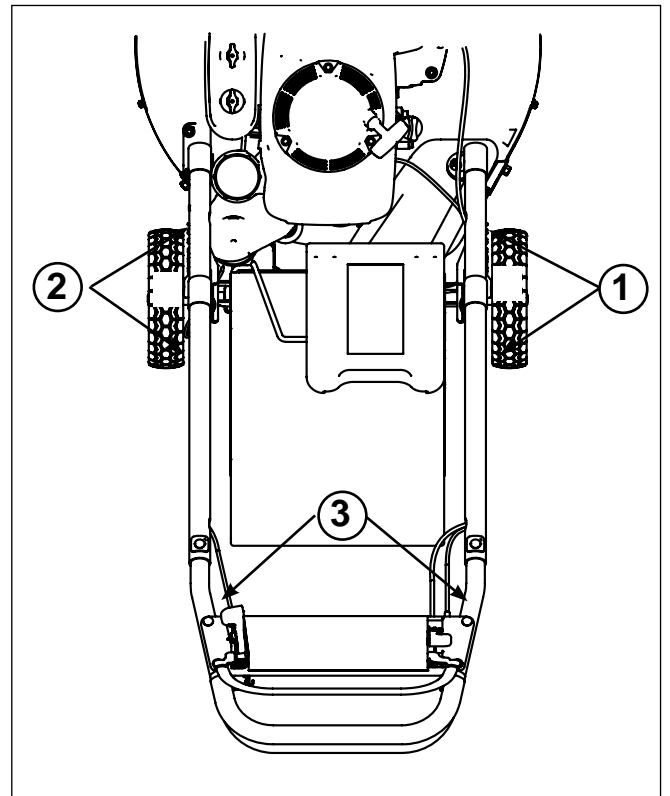

STEP 4

Insert the throttle cable inside the left handle tube. Pull the cable through the inside hole of the tube. Install the throttle cable to the engine per the illustration. Install the edge of the cable sheath in line with the edge of the clamp as illustrated.

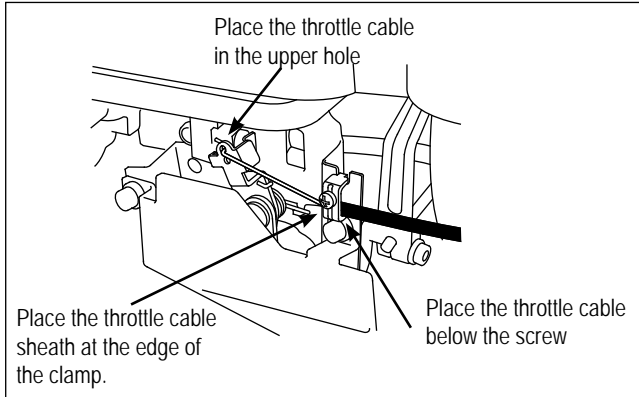

STEP 5

Verify that the throttle control is adjusted properly as follows:
 - Move the throttle control to the Full Throttle position.

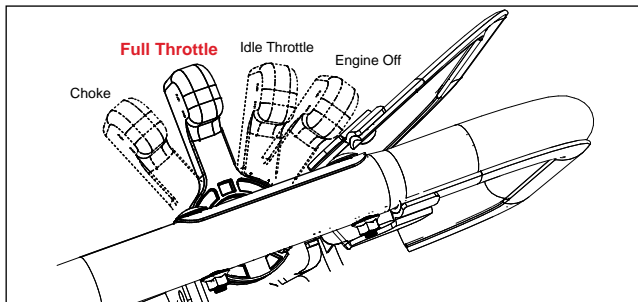

- In the full throttle position the two arms at the throttle mechanism on the engine should touch as illustrated below.

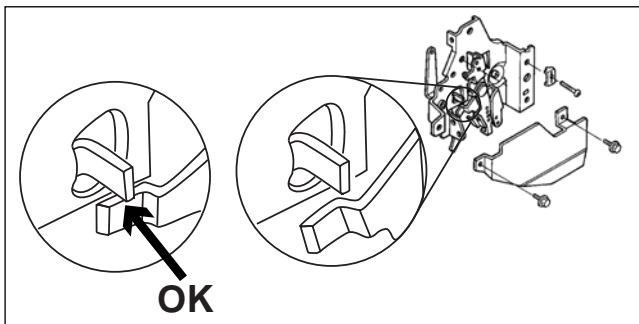

Following these steps for the throttle adjustment will ensure that the Honda engine performs properly for this mower. The engine speed is adjusted to approximately 3500 RPM at the factory.

NOTICE:

The engine speed should preferably be checked and verified with a tachometer. Normal full throttle speed of the engine should be adjusted to 3500 RPM. An authorized Honda Engine Dealer can verify and adjust the engine speed properly.

STEP 6

Install the blade brake clutch cable into the plastic arm on the control panel as illustrated.

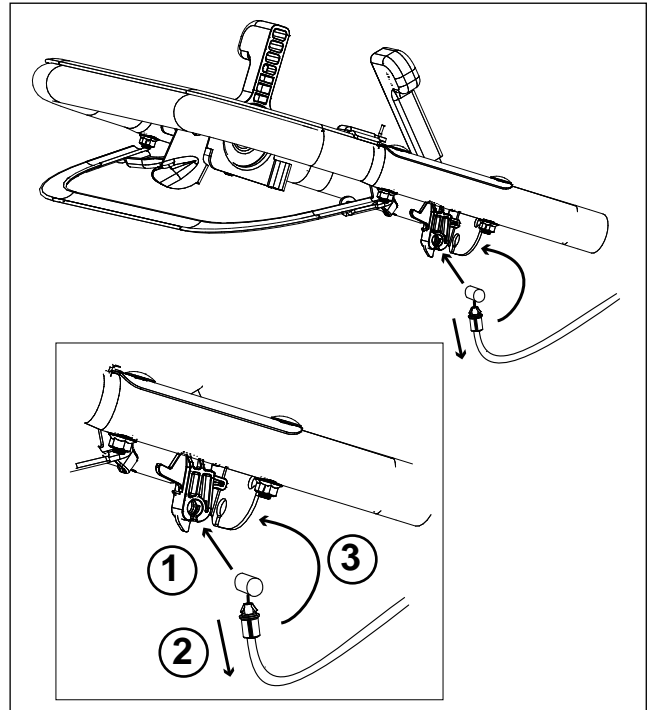

Insert the barrel shaped cable fitting into the hole on the plastic arm (1). Pull down on the cable sheath (2) and insert into the hole in the control panel (3)

STEP 7

To assist with the installation of the drive cable to the lower control bar push the control bar past the spring lock (1) that normally retains the control bar in a comfortable operating position.

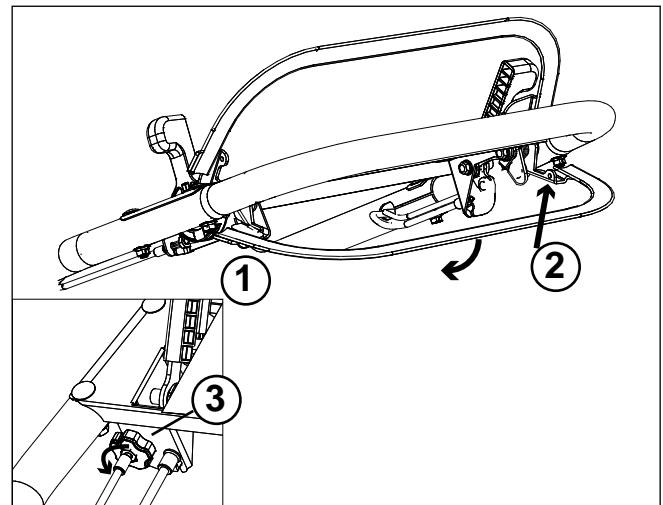

Insert the end of the spring into the hole (2) in the control bar.
 - Pull back on the cable adjustment knob and insert into the slot of the control panel.
 - For initial set-up turn the drive cable adjustment (3) all the way counter clockwise. For correct adjustment see the Operator's Manual - page 11.
 - Pull up on the control bar to check the function.